

---

---

## NEEDLE DEPTH ADJUSTMENT

---

---

### PURPOSE:

The needle must rise 2-3 mm from bottom dead center to form a loop behind the needle. As the hook point passes behind the needle it captures the formed loop. If the needle depth is too high or too low, the hook will be unable to capture the loop. The stitch will not form properly and sewing quality is affected

### CAUSES:

- ◆ Red Caps worn or broken
- ◆ Needle Breaking or Bending
- ◆ Sewing into the hoop
- ◆ Changing needle brands

### SYMPTOMS:

- ◆ Skipping Stitches
- ◆ Looping
- ◆ Fraying
- ◆ Breaking Thread

---

### TOOLS NEEDED

3mm Hex Key (Allen Wrench)  
No. 1 Philips Head Screwdriver  
Flashlight

---

### PROCEDURE:

1. Using the Automat/ Controller, position sewing head to needle 2.
2. Power down embroidery machine.
3. Remove bobbin case from Hook Assembly.
4. Rotate hand wheel so needle is at its lowest point (Bottom Dead Center). (Zero degrees on the degree wheel is Bottom Dead Center.)
5. Before making any adjustments, see if lower half of needle eye is visible inside hook basket (what the bobbin case snaps into). See figure 1.

*If needle eye looks out of position, proceed to Step 6.*

*If needle eye looks correct, no adjustments are necessary. You may have a different problem*

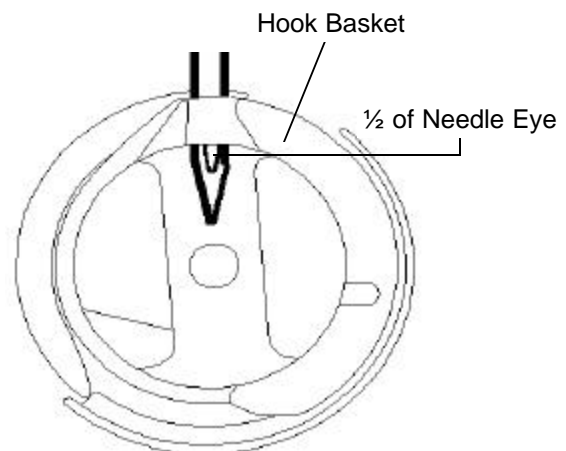
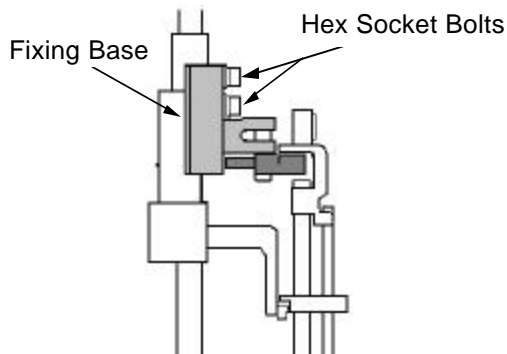
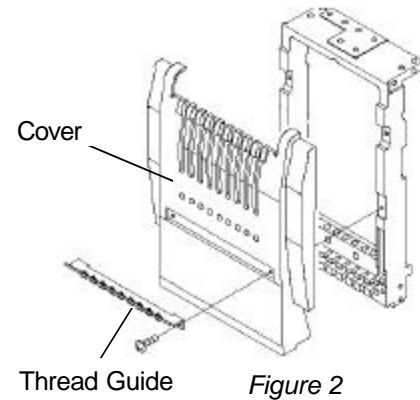



Figure 1

such as hook timing.

- Using a Philips head screwdriver, remove thread guide and cover from front of sewing head. See figure 2



- Using a 3mm hex key (allen wrench), loosen top and bottom hex socket bolts on Needle Bar Driver Fixing Base. See figure 3

	<b>Helpful Hint:</b> <u>If the eye of the needle is difficult to see:</u> Press down on top of the needle bar to see the entire eye then slowly let the needle bar rise until you see one half to three quarters of the eye.
---	---

- Adjust needle depth by moving the Needle Bar Driver up or down so half of the needle eye is visible in Hook Basket.
- While holding Needle Bar Driver in place, tighten lower hex socket bolt with 3mm hex key.
- Recheck needle depth, as it may have slipped while the bolt was tightened.
- Tighten upper hex socket bolt in the Needle Bar Driver Fixing Base.
- Reinstall Bobbin case.
- Replace sewing head cover and thread guide.
- Perform a sew test using the "HOX" pattern included with this manual.

If the problem still persists, you may have a different problem such as hook timing. If you suspect the hook is out of time, refer to the next chapter in this manual called "Hook Timing".

---

---

## HOOK TIMING

---

### PURPOSE:

Hook timing is the proper position of the Hook Assembly in relation to the needle in order to pick the thread off the needle and form a stitch. If the Hook point comes across at the wrong time or is too far or too close to the needle, the stitch will not form properly. The hook assembly is directly attached to the drive shaft eliminating the need to routinely re-time it.

### CAUSES:

- ◆ Something caught in Hook Assembly
- ◆ Needle breaking
- ◆ A build up of thread behind the Hook
- ◆ Drastic change of needle size

### SYMPTOMS:

- ◆ Skipping Stitches
- ◆ Looping
- ◆ Fraying
- ◆ Breaking Thread

---

### TOOLS NEEDED

- 2.5mm Hex Key (Allen Wrench)
  - Slotted Screwdriver
  - Flashlight (Optional)
  - A Friend to Help (Optional)
- 

### PROCEDURE:

1. Ensure Needle Depth is correct. *(See chapter titled Needle Depth)*
2. Using the Automat/ Controller, position the sewing heads to needle 1.
3. Power down embroidery machine.
4. Using 2.5mm hex key, remove throat plate screws and throat plate. *See figure 1*
5. With finger, check entire Hook Assembly for burrs, nicks, or rough spots.

*If there are burrs, nicks, or rough spots, polish them out using a very fine emery cloth and then crocus cloth.*

*If the Hook has deep burrs or nicks, or you are planning to replace the Hook, see chapter titled Hook Assembly Replacement*

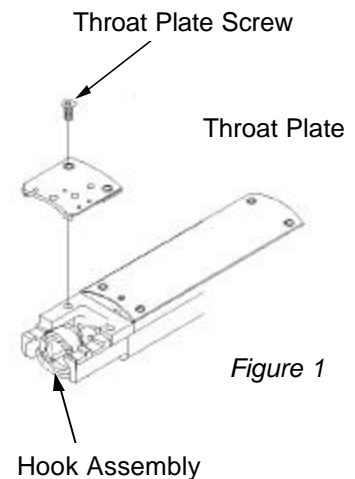

Figure 1

6. Rotate handwheel so hook spins counter-clockwise and stop when Hook Point is directly behind needle. (This should occur at 24° on degree wheel) See figure 2
7. Before making any adjustments, check hook timing. Hook Point should cross behind needle in middle of scarf of needle and approximately 1-2 threadwidths away from needle. See Figure 3

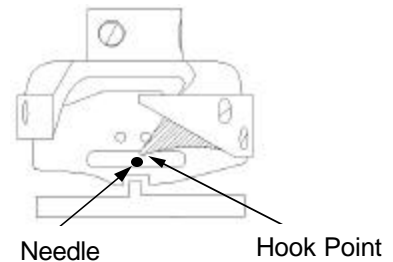

Figure 2

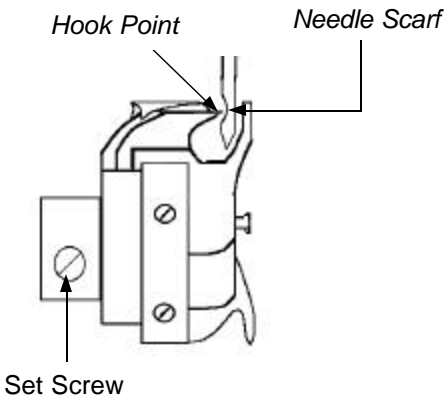

Figure 3

If hook timing needs adjustment proceed to step 8.

If the hook timing looks correct, no adjustment is necessary.

8. Loosen the 3 set screws on Hook Assembly by rotating handwheel until screw is accessible, then loosening it with slotted screwdriver. (Screws can be accessed at degree wheel settings 110°, 170°, and 230°)
9. Rotate Handwheel so needle reaches lowest point.(0° on degree wheel) Be sure Hook Assembly is spinning **counter-clockwise**.

**Note:** You may want to have someone help by rotating the handwheel while you hold the Hook Assembly in position, or leave one of the set screws slightly tightened. Otherwise the Hook Assembly will slide around causing the needle to break while the handwheel is turned.

10. Continue to rotating handwheel until needle rises 2-3mm (24° on degree wheel). Middle of needle scarf will be even with outer edge of Hook Assembly. See Figures 2 & 3

11. Position Hook Point directly behind needle, and approximately 0.5mm away from the hook. Hook Point should cross behind needle in middle of needle scarf.



**Helpful Hint:** If you have difficulty setting gap between Hook Assembly and Needle:

Before setting the timing, take your needle out and turn it around backwards. This allows the needle scarf to be facing you, and you can bring the Hook Point up until it just barely touches the needle. Be sure to turn the needle back around when you are finished!

12. Tighten Hook set screw most easily accessible. (One on underside of hook assembly is usually easiest to reach)
13. Tighten rest of set screws on Hook Assembly by rotating handwheel until screw is accessible, then tightening it with slotted screwdriver. (Screws can be accessed at degree wheel settings 110°, 170°, and 230°)
14. Rotate handwheel until hook point is directly behind needle.
15. Re-check timing and gap as hook may have slipped while screws were being tightened.
16. Re-install Throat Plate and Bobbin Case.
17. Perform a sew test using the “HOX” pattern included with this manual.